

# ZXEPG E260C8 Industrial and Commercial Energy Storage Integrated Cabinet Datasheet

## Product Introduction



Durasol Energi in collaboration with ZTE has launched a new generation of 125kW/261kWh C&I integrated energy storage cabinet, designed to meet the demand for efficient, reliable, and flexible energy storage solutions in the C&I fields.

- This innovative product integrates energy storage, intelligent management, and rapid response, equipped with a high-density battery pack boasting a total capacity of up to 261kWh, ensuring sufficient power reserves to address grid fluctuations, peak-valley electricity price differentials, and emergency backup power needs.
- With a single cabinet output power of 125kW, it can be used in parallel, meeting the power requirements of most application scenarios. It incorporates advanced BMS and EMS systems for real-time battery status monitoring.
- Multiple safety protection mechanisms ensure stable operation, while the modular design facilitates installation and maintenance. It can be flexibly applied to various scenarios, helping enterprises reduce energy consumption and emissions, optimize operational costs, promote renewable energy integration, and drive green, efficient, and sustainable future development.

## Product Highlights

### Safe and reliable

- Active safety monitoring and fire extinguishing
- Multiple fire protection measures and step-by-step protection

### Economical and efficient

- Zero parallel battery pack, no circulating current
- Optimal fitting of equipment efficiency, system efficiency  $\geq 90\%$

### Flexible and convenient

- Integrated design, plug and play
- Single cabinet automatic control, supporting multi cabinet AC parallel connection

### Fine management

- Thermal runaway warning, fire linkage
- Online upgrade, the system is constantly refreshed



## Technical Parameters

Product Model	ZXEPG E260C8
<b>Battery side parameters</b>	
Cell type	LFP/3.2V/314Ah
Pack model	1P65S*4
Grouping method	1P260S
Nominal power consumption	261kWh
Nominal voltage	832Vdc
Battery voltage range	728~936Vdc
Charge and discharge rate	0.5C
Cycle Life	8000 times@25°C/90%DOD/70%EOL
<b>PCS parameters</b>	
Rated output power	125kW
Maximum output power	138kW
Current distortion rate	<3%
Rated output current	180A
Maximum output current	200A
Rated output voltage	230/400Vac
Allowable grid voltage range	-15%~10%
AC output type	Three-phase four-wire (3W+N+PE)
Rated grid frequency	50 Hz/60 Hz
Overload capacity	110%, 10 min
Adjustable range of power factor	-1.0 (leading) ~ 1.0 (lagging)
On-grid Switching to Off-grid Time	< 20ms
<b>Efficiency</b>	
Max. Efficiency	≥90%
<b>Protection function</b>	
Function	Short circuit protection , reverse polarity protection , DC voltage protection , overcurrent protection , overtemperature protection , communication fault protection , cooling system fault protection.
<b>Basic Parameters</b>	
size(W*D*H)	1175*1300*2228mm (without lifting ring)
weight	About 2700kg
cooling model	Liquid Cooling
Protection level	IP54
Corrosion resistance grade	C4
Working temperature range	-20~55°C (derating above 45 °C)
Working humidity range	0~85% (non-condensing )
altitude	≤ 4000m(derating above 2000m)
Noise	≤ 75 dB (0.5 P, 25 °C下, 1 m)
Communication interface	4G/CAN/RS485/Ethernet
Number of parallel machines	On-grid : Max. 8 sets; Off-grid : Max. 3 sets
Fire protection system	Active detection + aerosol firefighting
Certification	GB/T36276, IEC62619, IEC/EN61000-6-2/4, UN38.3



## 1. User-Side ESS On-Grid Solution

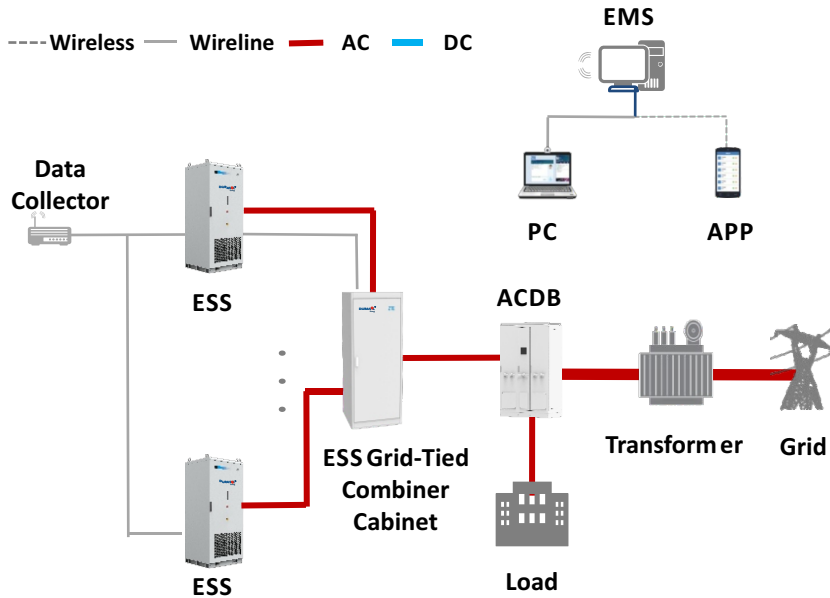

### Applicable Scenarios:

Independent energy storage for small to medium-sized industrial and commercial users (for strong grid scenario).

### Operating Modes:

- ✓ **Peak-load shifting:** Charge at low prices, discharge at peak price to profit from price differences.
- ✓ **Demand management:** Automatically discharge when power usage exceeds limits, reducing demand charges.
- ✓ **Capacity expansion:** Replace transformer upgrades with storage, saving capacity fees.

## 2. PV + ESS On-Grid Solution

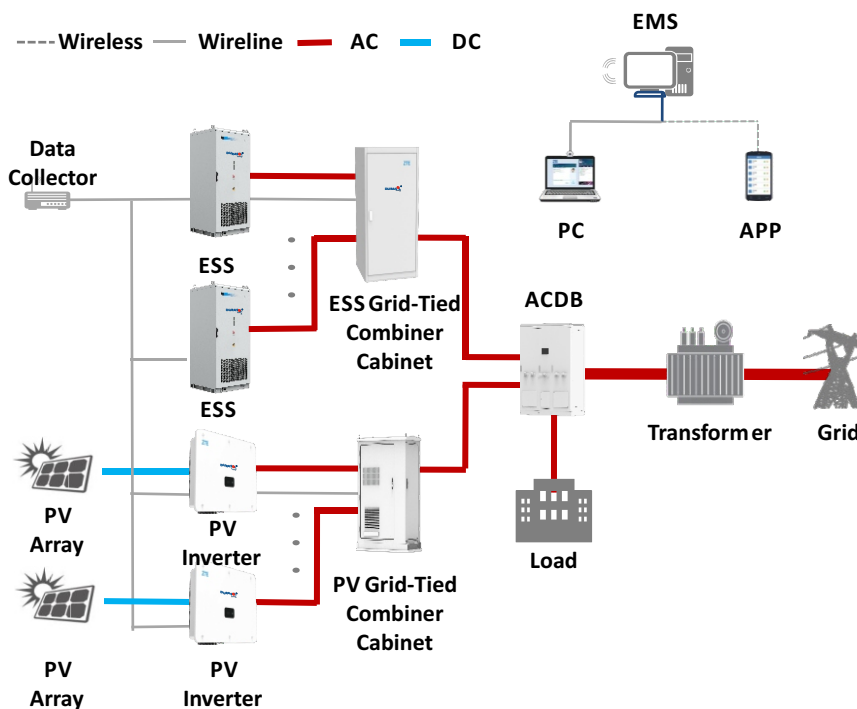

### Applicable Scenarios:

PV and ESS for small to medium industrial and commercial users (for strong grid scenario).

### Operating Modes:

- ✓ **Energy time shifting:** PV energy supply to the load firstly, and the remaining power is stored in ESS. When PV is insufficient, ESS discharge to the load. Maximize the benefits of electricity consumption.
- ✓ **Demand management:** Automatically discharge when power exceeds limits, reducing demand charges.



### 3. PV + ESS + DG On-Grid and Off-Grid Switching Solution

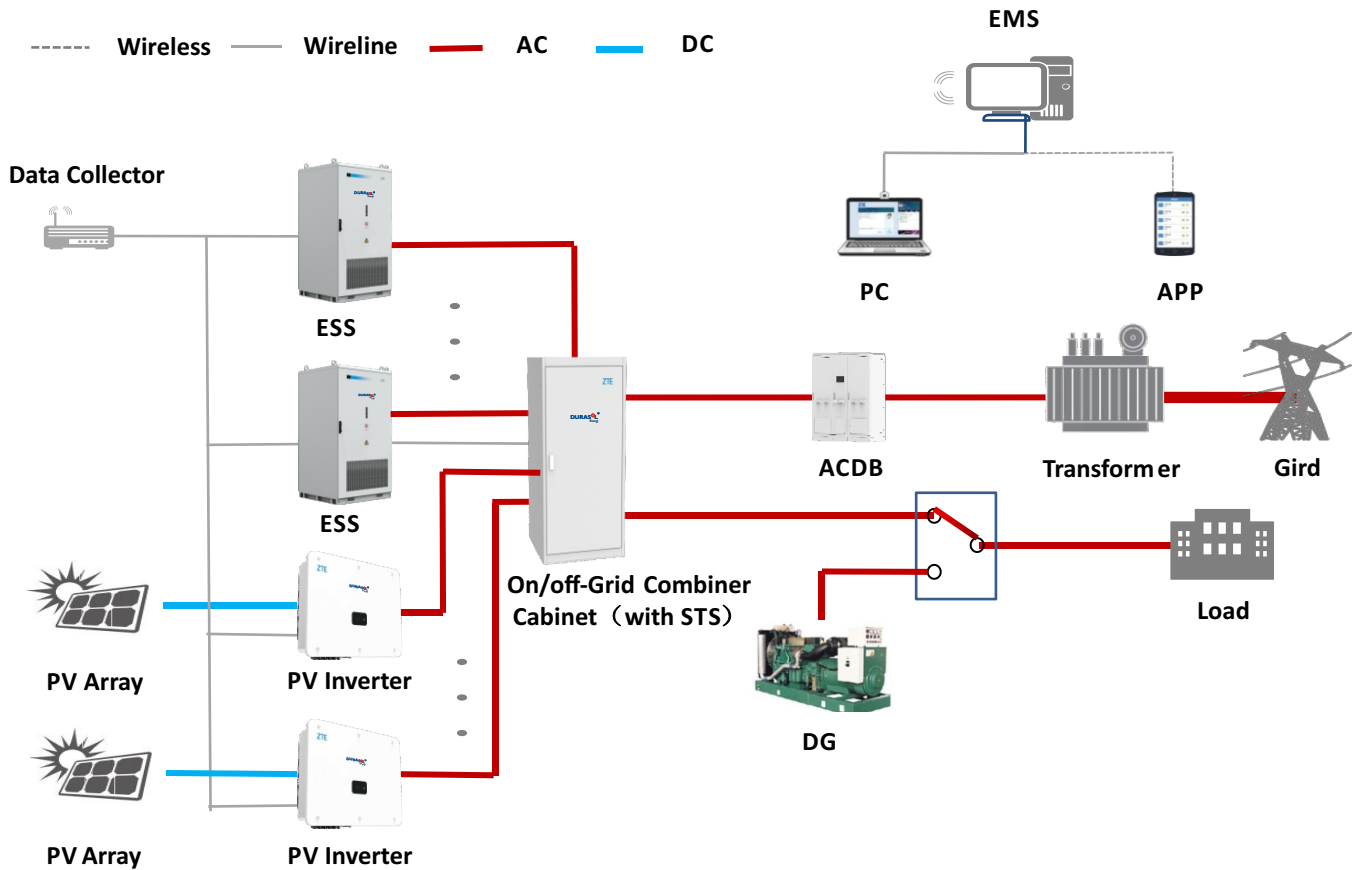

#### Applicable Scenarios:

PV + ESS + DG for small to medium industrial and commercial users to supply to the load on-grid and off-grid (for weak, or off-grid scenario ).

#### Operating Modes:

- ✓ **Backup power supply:** Charges when the grid is powered and discharges when the grid is out, providing emergency power during outages or power restrictions.
- ✓ **Energy time-shifting:** Prioritizes storing photovoltaic energy and supplies power to the load when photovoltaic generation is insufficient, maximizing the use of photovoltaic power to save costs.
- ✓ **Demand management:** When real-time power exceeds transformer capacity, the energy storage automatically discharges to reduce demand charges.